



OWNER'S MANUAL

Touch Panel E1

# TASC511 Round head buttonhole machine



Dahao public account

Dahao service cloud

V 2022-06

Copyright © 2022 DAHAO Technology  
版权所有，严禁擅自转载。

## **Foreword**





Thank you for using Dahao Computerized Control System for Special Sewing Machine.

It is appreciated that you do read this manual carefully in order to operate the machine correctly and effectively. If the user operates the machine contrary to regulations herein, thus cause loss to user or third party, we will not take responsibility. Besides, you should keep this manual for future use. For any fault or problem of machine, please ask the professionals or the technicians authorized by us for repair service.













## Safety Matters for Attention



### 1. Signs & Definitions of Safety Marks













This User's Manual and the Safety Marks printed on the products are to enable you to use this product correctly so as to be away from personal injuring. The signs and definitions of Marks are shown in below

 <b>Danger</b>	The incorrect operation due to negligence will cause the serious personal injury or even death.
 <b>Caution</b>	The incorrect operation due to negligence will cause the personal injury and the damage of mechanism.
	This kind of marks is "Matters for Attention", and the figure inside the triangle is the content for attention. (Exp. The left figure is "Watch Your Hand!")
	This kind of mark is "Forbidden".
	This kind of mark means "Must". The figure in the circle is the contents that have to be done. (Exp. The left figure is "Ground!")

### 2. Safety Matters for Attention

 <b>Danger</b>	
	For opening the control box, please turn off the power and take away the plug from socket firstly, then wait for at least 5 minutes before opening the control box. Touching the part with high voltage will cause the person injury.
 <b>Caution</b>	
<b>Using Environment</b>	
	Try not to use this sewing machine near the sources of strong disturbance like power cable disturbance and static disturbance. The source of strong disturbance will affect the normal operation of the sewing machine.
	The voltage fluctuation shall be within $\pm 10\%$ of the rated voltage. The large fluctuation of voltage will affect the normal operations of sewing machine, and the regulator will be needed in that circumstance
	Working temperature: $0^{\circ}\text{C} \sim 45^{\circ}\text{C}$ . The operation of the sewing machine will be affected by environment with temperature beyond the above range.
	Relative Humidity: $35\% \sim 85\%$ (No dew inside the machine), or the operation of sewing machine will be affected.
	The supply of the compressed gas should be over the consumption of the sewing machine. The insufficient supply will be cause the abnormal operation of the machine.
	In case of thunder, lightning or storm, please turn off the power and pull plug out the socket. Because these will have the influence on the operation of sewing machine
<b>Installation</b>	
	Please ask the trained technicians to install the sewing machine.
	Don't connect machine to power supply until the installation is finished. Otherwise the action of sewing machine may cause personal injury once the start switch is pressed by mistake.
	When you tilt or erect the head of sewing machine, please use both of your hands in that operation. And never press the sewing machine with strength. If the sewing machine loses its balance, it will fall into floor thus causes the personal injury or mechanical damage.
	Grounding is a must. If the grounding cable is not fixed, it may cause the electric-shock and mis-operation of machine

	The entire cables shall be fixed with a distance at 25mm away from the moving component at least. By the way, don't excessively bend or tightly fixed the cable with nails or clamps, or it may cause the fire or electric shock.
	Please attach the safety cover at the head.

<b>Sewing</b>	
	This sewing machine can only be used by the trained staff.
	This sewing machine has no other usages but the sewing.
	When operating the sewing machine, please remember to put on the glasses. Otherwise, the broken needle will cause the personal injury.
	At following circumstances, please cut off the power at once so as to avoid the personal injury caused by the mis-operation of start switch: 1. Threading; 2. Replacement of needles; 3. The sewing machine is left unused or beyond supervision
	At working, don't touch or lean anything on the moving components, because both of the above behaviors will cause the personal injury or the damage to the sewing machine
	During working, if the mis-operation happens or the abnormal noise or smell is found at the sewing machine, user shall cut off the power at once, and then contact the trained technicians or the supplier of that machine for solution.
	For any trouble, please contact the trained technicians or the supplier of that machine.
<b>Maintenance &amp; Inspection</b>	
	Only can the trained technicians perform the repair, maintenance and inspection of this sewing machine.
	For the repair, maintenance and inspection of the electrical component, please contact the professionals at the manufacturer of control system in time.
	At following circumstances, please cut off the power and pull off the plug so as to avoid the personal injury caused by the mis-operation of start switch: 1.Repair, adjustment and inspection ; 2. Replacement of the consumptive devices, like needle, knife and so on.
	Before checking, adjusting and repair any air-driven equipment, user needs cut off the source of gas and wait for the pressure indicator drop to "0".
	If you have to adjust the machine when the power is on, you can't be too careful at following the entire Safety Matters for Attention
	If the sewing machine damages due to the unauthorized modification, our company will not be responsible for it.

# Contents

1 General Information.....	2
1.1 General.....	2
1.2 Functions & Parameters.....	2
1.3 Shape of Stitch Form.....	3
1.4 Standardization.....	4
1.5 Operation Method.....	4
2 Basic Operating Instruction.....	5
2.1 Basic Operation.....	5
2.2 Setting Methods of Patten Program.....	6
2.3 Confirm Pattern under Test Feed Mode.....	12
2.4 Shift of Knife Actions.....	15
2.5 Method for Shifting Cloth Position.....	16
2.6 Threading Mode.....	17
3 Instructions on Sewing Operations.....	18
3.1 Auto Mode.....	18
3.2 Manual Mode.....	19
3.3 Pause Switch.....	21
3.4 Usage Instructions on Cyclical Sewing Function.....	23
4 Interface of Parameter Setting Mode.....	26
4.1 Description of Functions.....	27
4.2 Software Version Inquiry.....	27
4.3 Lightness Adjustment.....	28
4.4 Error Information Record.....	28
4.5 Communication Function.....	29
4.5.1 Operation Penal Update.....	29
4.6 Parameter Setting.....	33
4.6.1 Method for Setting Parameters.....	33
4.6.2 List of Parameters at U Level.....	35
4.7 Initialization of Parameters.....	41
4.8 Parameter Back-up & Recovery.....	42
5 Appendix 1.....	43
5.1 List of Warning Information.....	43
5.2 Hint List.....	46
5.3 Malfunction Settlement.....	48
6 Appendix 2.....	50
6.1 Installation Size of Control Box.....	50
6.2 Installation Size of Control Box.....	50
6.3 Machine System Diagram.....	51

# 1 General Information

## 1.1 General

TASC511 Series Computerized Control System for Sewing Machine is characterized by the advanced technology it adopted. Its main shaft motor features large torque, high efficiency, stable running and low noise by adopting the advanced AC Servo Control Technology; its operating panel can meet various demands from clients in attaching; its structure of system is designed in German style which is easy to repair and install; and its system control software can be updated via U disk, providing convenience to client in improving the function of product continuously.

## 1.2 Functions & Parameters

For the functions and parameters of TASC511 Series AC Servo System, please refer to Table 1:

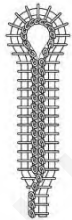

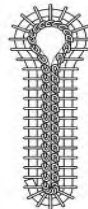
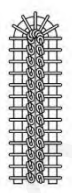
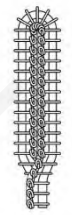
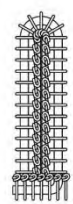
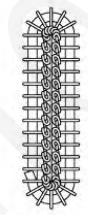

Table 1: Comparison of Functions & Parameters

No.	Items	Model	TASC511
1	Usage		Man's cloth, Women's dress, Leisure wears, Jeans and Trousers
2	Sewing Speed		1000—2700rpm
3	Shapes of Stitch Form		Without Bar-tacking Sewing
			Taper bar-tacking Sewing
			Linear bar-tacking Sewing
			Round Bar-tacking Sewing
			Radial Tacking
4	Length of Buttonhole		Eyelet 8-42mm、 Linear Buttonhole 5-50mm
5	Stitch Form Pitch		0.5-2.0mm
6	Stitch Form Width		1.5mm—5.0mm, Mechanical adjustment:1.5—4.0mm
7	Length of Taper Bar-tacking		0-20mm
8	Presser Height		Standard 12mm (Max 16mm)
9	Start Mode		Double-pedal Switch or Hand Switch
10	Cloth-feeding Mode		X/Y/Z 3 Pulse Motor Intermittent Feeding
11	Drive Mode for Trimming Upper/ Bottom Thread		Driven by Solenoid Valve
12	Drive Mode of Knife		Driven by Solenoid Valve

13	Safety Device	Emergency Stop Switch, Head Turn-over Switch and Circuit Automatic can Protection Function
14	Method for Pattern Input & Update	U Disk
15	Available Language in Operation Panel	Chinese & English
16	Upper Axis Motor	Small AC Servo Motor 750W, Belt Transmission Drive Mode
17	Air Pressure	Main Adjuster: 0.5MPa; Air-hammer Pressure Adjuster:0.4Mpa
18	Power Consumption	600W
19	Operation Temperature Range	0°C~45°C
20	Operation Humidity Range	35%~85% (No Dew Condensation)
21	Line Voltage	AC 220V ± 10%; 50/60Hz

※ Effective standard for product:QCYXDK0004—2022 《Computerized Control System for Industrial Sewing Machine》 .

### 1.3 Shape of Stitch Form

Eyelet Buttonhole			
			
No Bar-tacking	Taper Bar-tacking	Linear Bar-tacking	Round Bar-tacking
Linear Buttonhole			
			
No Bar-tacking	Taper Bar-tacking	Linear Bar-tacking	Round Bar-tacking
Radial Hole			
			

#### **1.4 Standardization**

The functional keys attach the figures known by the public. Because the figure is the internal language, users from any country can recognize it.

#### **1.5 Operation Method**

By using TFT touching-panel screen, this system features the user-friendly interface and easy operation. For specific method of operation, please refer to the operating instruction.

## 2 Basic Operating Instruction

### 2.1 Basic Operation

#### ① Turn on Power

After user turns on the power, the system will display the contents at below in order at the Pattern Data Display Area:

Welcome to using TASC511 Buttonhole Machine  
→TASC511-00 (01or 02) →Create Data→ Please Start Switch.

Note: If figure “E-012” is displayed on the operation panel A when user turns on the power supply, please turn the wheel (1) in the directions shown in figure B and make the print (2) face to the gap (3) directly



(A)

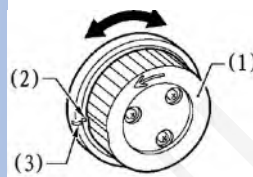

(B)



## ② Step Pedal for Start

After user stepped the right pedal for start, the feeding board will move to the position where the cloth is located. In the operation panel, the readiness status of the previous operation mode (it might be Auto Mode, Manual Mode, Test Mode, Cycle Mode or Program Mode) will be displayed.

Note: The “Readiness Status” is the status before the next action when the system moves to a mode.



## 2.2 Setting Methods of Patten Program

### 2.2.1 Interface for Inputting Sewing Data

The data input interface is shown in the right figure. For detailed functional instructions, please refer to Table 1: Button Instruction Table.

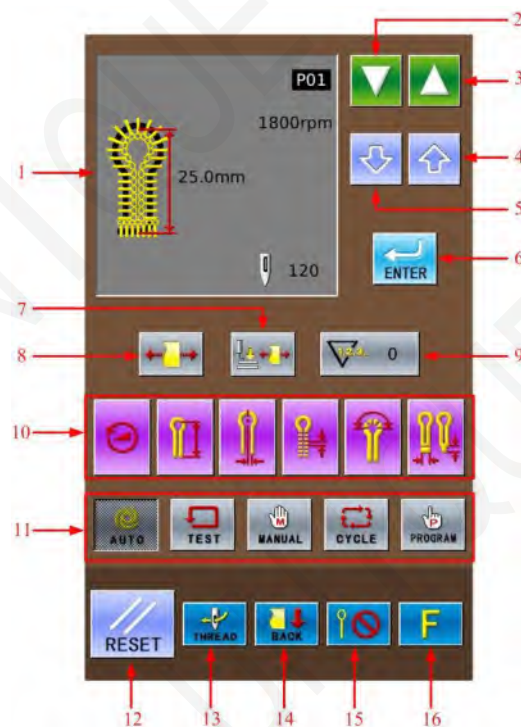

























Table 1: Button Instruction Table:

No.	Figure	Functions	Remarks
1		Display of Sewing Shape	Display the pattern number, patten shape, length, stitch number, sewing speed and so on.
2		Decrease Number of Software & Parameter	

No.	Figure	Functions	Remarks
3		Increase Number of Software & Parameter	
4		Increase Value & Parameter Content	
5		Decrease Value & Parameter Content	
6		ENTER (Confirmation) Key	Confirm the parameter and the pattern data.
7		Cloth-tightening before presser down:  Cloth-tightening after presser down: 	The default setting is the Cloth-tightening after Presser Down. If user sets it as Cloth-tightening before Presser Up, this parameter will return to default setting when one pattern is finished
8		Cloth-tightening Permitted:  Cloth-tightening Forbidden: 	The default setting is the Cloth-tightening Permitted. If user sets it as Cloth-tightening Forbidden, this parameter will return to default setting when one pattern is finished.
9		Display the value in Counter	
10		Hot Keys	Quickly change 6 parameter relating to the pattern
11		Sewing Mode	Five available sewing modes: Auto, Manual, Test, Cycle and Program
12		RESET	Release the display of incorrect information
13		THREAD	Have access to the threading mode
14		FRONT:  BACK: 	Shift the positions of the feeding board. Alternative positions: Front & Back.
15		Cut-before-Sewing:  Cut-after-Sewing:  Non-Cut: 	Set the actions of knife
16		Parameter Management	Have access to parameter setting



### 2.2.2 Setting of Pattern Program

It is advised to preset the pattern data parameters which are frequently used so that user would only need to select the pattern code to have access to the set pattern in the future usage, thus saves the time for resetting the parameters at each time.





The 20 patterns can be registered at most, whose parameters can be altered at any time.

When leaving the factory, pattern codes from P01 ~P20 save the default pattern program (The patterns from P01 ~ P20 are all the same.)

- ① Press 
- ② Select a pattern code from P01~P20 (1) for changing the content.

Pattern code (1) will change in the following sequence: P01 → P02 → ... P20 → C1→C2...C9, at each pressing . (press  to change the code in the contrary direction.)







- ③ Press 
- The pattern data display area will display the parameter code (2) and the specific parameter information (3) at previous time.

- ④ Press   to select the parameter code (2)
- ⑤ Press   to change the content of parameter(3).

The shining parameter information (3) means the content is uncertain

- ⑥ Press  to confirm the changed content.

If the parameter information is still, that means it has been confirmed. If user

presses any key among , , , ,  instead of  at (3) shining, the changed parameter (3) will be abandoned and return to the original value.

- ⑦ Repeat the operation from 4 to 6 to change other parameters.

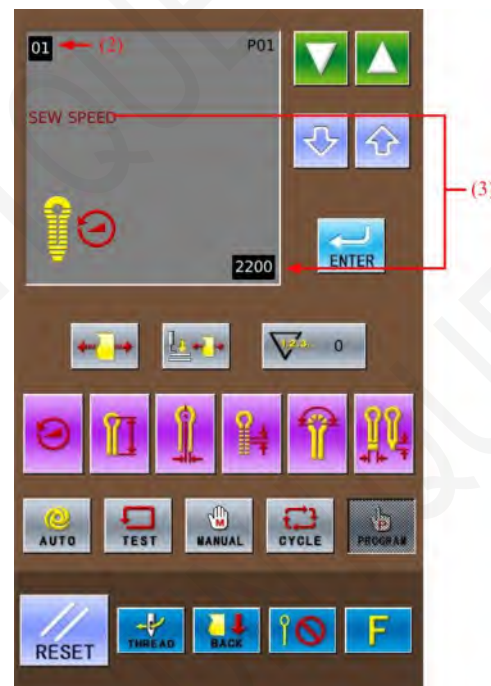
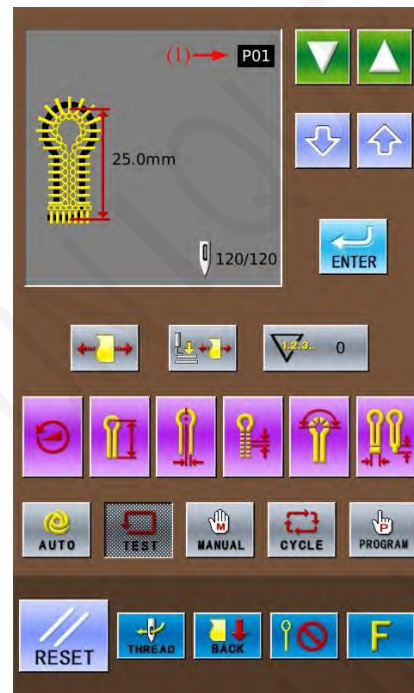

### 2.2.3 About Hot Keys

Among the Hot Keys (4), the following 6 parameters are registered for their frequent usage:





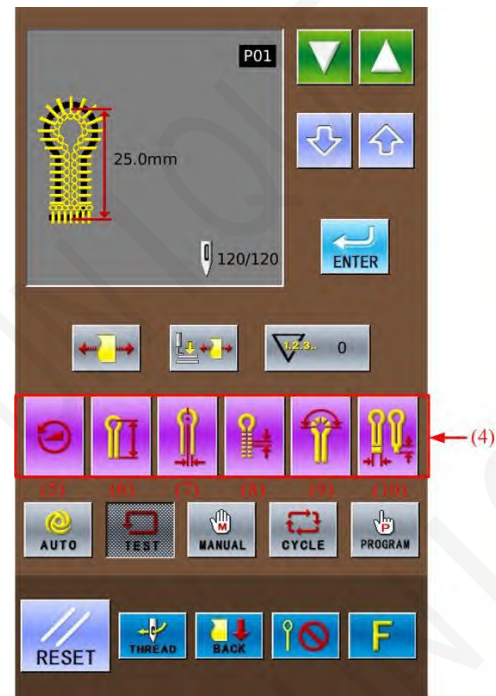

- (5)Sewing Speed (Parameter code No.01)
- (6)Length of Lockstitch Sewing at Buttonhole (Parameter code No.02)
- (7)Pitch of Knife ( Parameter code No.03)
- (8)Distance between Stitch Form (Parameter code No.04)
- (9)Stitch Number at Eyelet Part (Parameter code No.05)
- (10)Length of Bar-tacking (Parameter code No.06、No.08、No.10)













Note: The different bar-tacking sewing types set in parameter code No.40 are corresponding to the various values of bar-tacking sewing length parameter (10).



















### 2.2.4 List of Pattern Parameters at S level

According to the set content of other parameters, the default value of some parameters may be unchangeable or invalid.

Parameter Code	Content	Range	Unit	Default Value
S01	Sewing Speed 	1000~2700rpm	100	1800rpm
S02	Length of Lockstitch Sewing at Buttonhole 	5~50mm	0.5	25mm
S03	Pitch of Knife 	-2.5~0.5mm	0.05	0.2mm
S04	Distance between Stitch Form 	0.5~2.0mm	0.1	1.0mm
S05	Stitch Number at Eyelet Part 	4~20 Stitches	1	9 Stitches
S06	Length of Taper 	1~20mm	1	6mm
S07	Offset 	0.5~2.0mm	0.1	1.5mm

Parameter Code	Content	Range	Unit	Default Value
S08	Length of Linear Bar-tacking 	2.0~6.0mm (Each side at 3.0mm as MAX)	0.1	5.0mm
S09	Stitch Number of Linear Bar-tacking 	5~18 针	1	7 针
S10	Stitch Number of Round Bar-tacking 	5~17 针	1	7 针
S11	Shape of Knife 	1~6 (select the proper knife, according to the different knife code)	1	2
S12	Sewing Width Adjustment 	-1.0~1.0mm	0.1	0.0mm
S13	Eyelet Part Low Speed 	-600~0rpm (This parameter takes the default value of the parameter 01 sewing speed as standard.)	100	0rpm
S14	Speed of Linear Bar-tacking 	1000~2500rpm (if the sewing speed is lower than the linear bar-tacking speed, these two speeds will become equal.)	100	1800rpm
S15	Stitch Number of Slow-start 	0~3 Stitches	1	0 stitch
S16	Speed of Slow-start 	400~1500rpm (if the sewing speed is lower than the slow-start speed, these two speed will become equal)	100	700rpm
S17	Knife Adjustment in X Direction 	-0.5~0.5mm	0.05	0.0mm
S18	Knife Adjustment in Y Direction 	-0.7~0.7mm	0.05	0.0mm
S19	Stitch number of bar-tacking at start 	0~4 针	1	0 针
S20	Stitch number of bar-tacking in end 	0~4 针	1	0 针
S21	Adjustment in X Direction	-1~6	1	0

Parameter Code	Content	Range	Unit	Default Value
				
S22	Adjustment in Y Direction 	-1~6	1	0
S23	$\theta 1$ Adjustment 	-3~3	1	0
S24	$\theta 2$ Adjustment 	-3~3	1	0
S25	Taper Bar-tacking Angle 	-5~5	1	0
S26	Adjustment on Bar-tacking Width 	-1.0~0.0mm	0.1	0.0mm
S27	Coincidence Amount of Bar-tacking 	0.0mm~2.0mm	0.1	1.0mm
S28	Adjustment of Bar-tacking in X Direction 	-1.0mm~1.0mm	0.1	0.0mm
S29	Adjustment of incline angle of Bar-tacking 	-3~1	1	0
S30	Round Head Correction	-25~25	1	0
S31	Pitch of bar-tacking at sewing-end 	20%~100%	5%	100%
S32	Stitch Number of Round coincidence 	1~4 Stitches (Within 45°)	1	1 Stitch
S33	Stitch moving when without cutting 	1~2	1	1
S34	Cutting Size of Radial Hole 	2~5mm	1	2
S35	Stitch Number of Radial 	8~100 Stitches	1	20
S36	Coincident Stitch Number of Radial Hole 	1~5 Stitches (Within 45°)	1	2
S37	Bar-tacking Pitch	0~30	1	0
S38	Reserved (For future use)			
S39	Pattern Copy	OFF~P01~P20	1	OFF

Parameter Code	Content	Range	Unit	Default Value
S40	Type of Bar-tacking 	1: No Bar-tacking 2: Taper Bar-tacking 3: Linear Bar-tacking 4: Round Bar-tacking	1	2
S45	Stitch adjustment/pattern generation method at the joint part	1. The panel board program of versions earlier than V104 is mainly used to adjust the stitch at the joint part of the eyelet portion. 2. As for the panel board program from V104, user can choose pattern-making mode: 0 means to use the previous pattern-making method, while 1 means to use the original pattern-making method.	0~1	

### 2.3 Confirm Pattern under Test Feed Mode

Test Feed Mode is that only cloth-feeding board works normally when the upper shaft keeps still. This mode is used to confirm the positional relation between needle and presser.

#### ① Press Test Key

Press  to display the stitch form (1), pattern code (2), total stitch number (3) and leftover stitch number (4) in the pattern data display area

#### ② Select the Pattern Code

The pattern code will change in the following sequence: P01 → P02 → ... P20 →

C1→C2...C9...P01 at pressing the .

(Press  to reverse this sequence.)

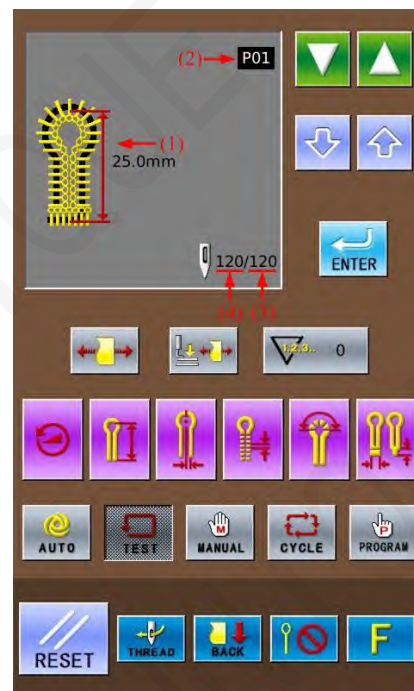

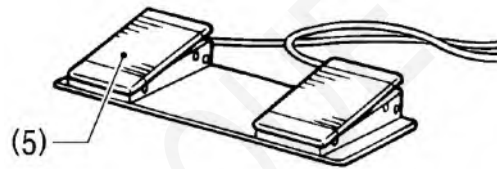

- ③ **Step Presser Pedal**  
Step the left pedal (5) to lower the presser

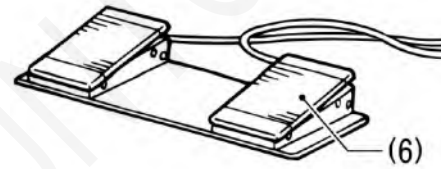

- ④ **Step the Start Pedal**  
Step the right pedal (6) to make the cloth-feeding board move to the position of sewing start.



- ⑤ **Step Pedal (6) or press**   **to start the sewing under Test Mode.**

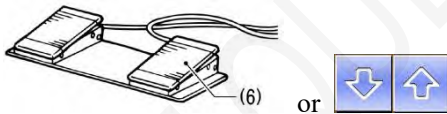

(2 stitches will be sewn at each pressing.)  
(Holding for continuous sewing)

Note: the leftover stitch number (4) displayed at the data display area will reduce 2 stitches at each time.

The buzzer will work at the last stitch.  
No thread-trimming actions and knife actions in test mode.



- ⑥ **If user wishes the cloth-feeding board to return to the cloth setting position at the ending of the test**

Please press Pause switch (7), and then

press .

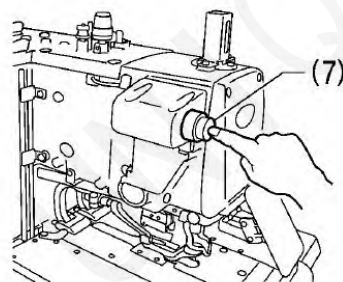

- ⑦ During the cloth-feeding, if user wants cloth-feeding board to return to the former sewing position:

Please press , 2 stitches will be returned at each pressing. The leftover stitch number (4) will add 2 stitches at each time.



- ⑧ Last Stitch

Step Start Pedal (6) until the leftover stitch number turns to 0 and the cloth-feeding board returns to the position for setting cloth. After that, the pattern data area will display “END OF TEST FEED MODE”.

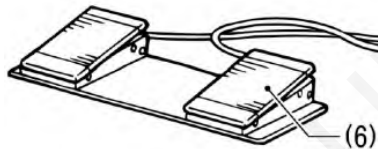

## 2.4 Shift of Knife Actions

### ① Non-Cut

No knife action during the sewing.

At this time, the interface shows as the picture at right. Press the Knife Mode Key to shift the status to Non-Cut (1).



### ② Cut-before-Sewing

The sewing actions are after the cutting.

In the interface shown as the right figure, shift the Knife Mode to the status of Cut-before-Sewing (2). At this time, this mode will be displayed in area (3).



### ③ Cut-after-Sewing

The sewing actions are before the cutting action.

In the interface as shown in right, press Knife Mode Key to shift the status to Cut-after-Sewing (4). At this time, this mode will be displayed at area (5).



## 2.5 Method for Shifting Cloth Position

Because this function can move the cloth-feeding board to a position more forward than standard position for setting cloth, it will be easy for setting the cloth. Especially at the status of Cut-after-Sewing, the time of the cycle is shortened.

### ① Move the cloth-feeding board to the front

In the readiness status of Auto mode, Test Feed mode or Manual mode, press Cloth Position Shift Key (1) to change the feeding

mode to . At this time, the cloth-feeding board will be moved to the Front (position of sewing start).

Note: Front is the position nearer to the operator when he faces to the machine.

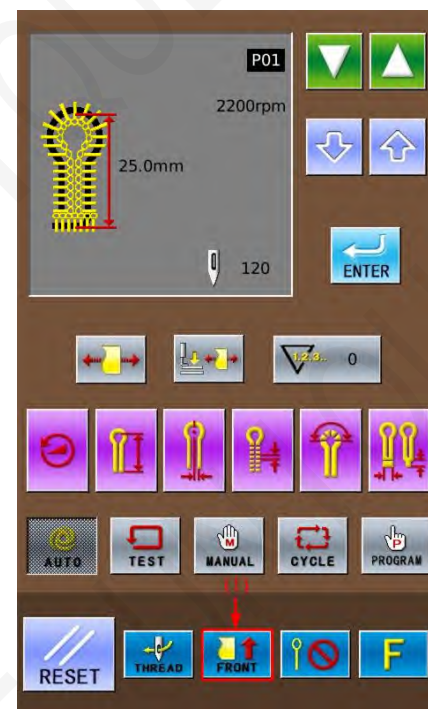

② **Move cloth-feeding board to backside (standard position for setting cloth)**

Press the Cloth Position Shift Key (2) again to change the cloth-feeding mode to . At the moment, the cloth-feeding board will return to the backside (the standard position for setting cloth).



## 2.6 Threading Mode

This mode is used in threading the upper thread. At threading mode, if the Z axis of needle rod turns 180 degree, the excitation of stepping motors on X, Y and Z axis will be cut off. At this time, the needle rod and cloth-feeding board can move freely so as to be easy for threading the upper thread.

① **Have access to threading mode**

In the readiness status of Auto mode, Test Feed mode or Manual mode, press Threading Mode Key (1) to shift from cloth-feeding mode to threading mode. At this time:

1. The pattern data display area will have “Threading mode press ‘RESET’ ” (2).
2. The thread-holder goes into open status.
3. The buzzer rings and the needle rod returns for 180°, then the excitation of the stepping motors on X, Y & Z axis will be cut off

② **Threading Upper Thread**

After 3 minutes, the thread-holder will be turned off automatically.

③ **Finish of Threading Upper Thread**

After threading the upper threads, please



When the needle rod and cloth-feeding board are moved to origin for origin test, they will return to the position for setting cloth.

The thread-holder is off.



## 3 Instructions on Sewing Operations





### 3.1 Auto Mode

- For the automatic sewing at first time, do please perform the trial sewing.
- When using TASC511 in the environment with low temperature, user shall perform the trial sewing for several times, so as to warm up the motor.

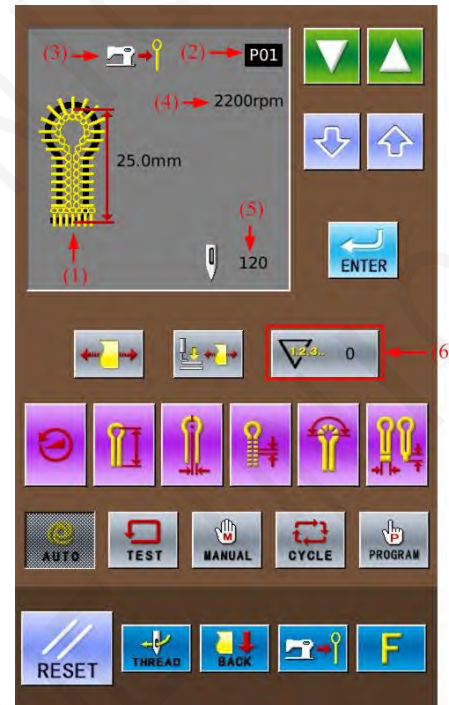
① Press Auto Mode Key

Press  to show the Shape & Length of sewing stitch: Pattern Shape (1), Pattern Code (2), Knife Action (3), Sewing Speed (4) and Total Stitch Number of Existing Pattern (5) at pattern data display area, as well as the Number of Production (6) at Production Counter Key.



- ② Press   to select the wanted pattern code (2). The pattern code will change in the following sequence: P01→P02→...P20→C1→C2...C9 at each pressing on . Press  to change the code in the contrary direction.

- ③ Select the wanted action of knife (Non-Cut/Cut-before-Sewing/Cut-after-Sewing).  
Note: For the detailed shift method of Knife Action, please refer to **【 2.5 Shift of Knife Actions 】**

- ④ Lay the fabric for sewing under the presser, step the presser pedal (7).

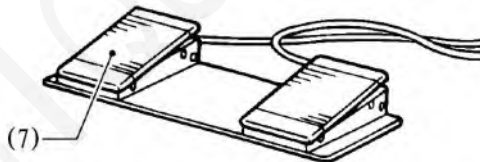

- ⑤ Step the start pedal (8) to start the sewing .

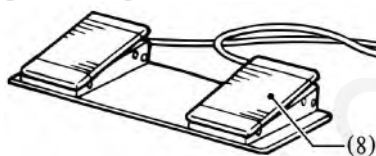

- ⑥ For sewing repetition, please repeat the operation in the 4<sup>th</sup> & 5<sup>th</sup> steps at above.

## 3.2 Manual Mode



Caution



Due to the knife will act during the manual sewing, please keep hand away from the knife. Otherwise the operator may suffer serious injury.



Under manual mode, turn the wheel to move the cloth-feeding board in stitch by stitch. This will simplify the operation in synchronizing adjustment of yarn-divider.

① Press Manual Mode

Shape of Sewing Stitch Form (1), Pattern Code (2), Knife Action (3), Total Stitch Number (4) and Leftover Stitch Number (5) are shown in the sewing data display area.

② Press  to select the wanted pattern code (2).

The pattern code (2) will change in the following sequence: P01→P02→... P20→ C1

→C2...C9 at each pressing on . (Press  to change the code in contrary direction.)

③ Lay the fabric for sewing under the presser, step the presser pedal (6) to lower the presser.

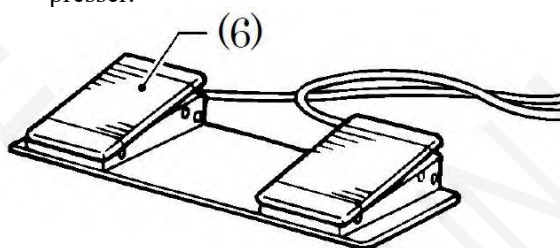

④ Step start pedal (7) to move the cloth-feeding board to the position of sewing start.

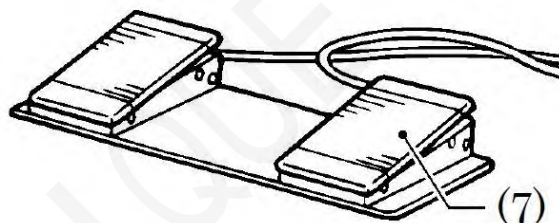

Caution:

When setting the knife action as “Cut-before-Sewing”, the operator shall look out for his hand at knife moving.

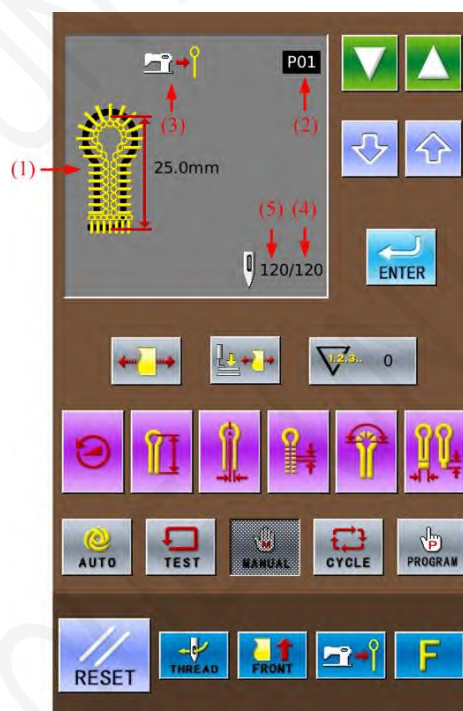

- ⑤ Turn Hand-wheel at Upper Axis to Left

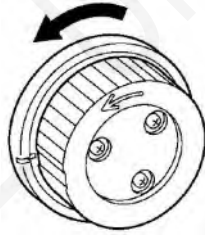

The cloth-feeding board will move to the sewing position of the next stitch at each turning round of upper axis hand-wheel. When the wheel reverses for half a cycle, the leftover stitch number (5) at sewing data display area will reduce 1 stitch



**Caution:**

If the upper axis hand-wheel turns reversely, the cloth-feeding board will not move the shape with the set stitch form. Please don't turn the wheel reversely.

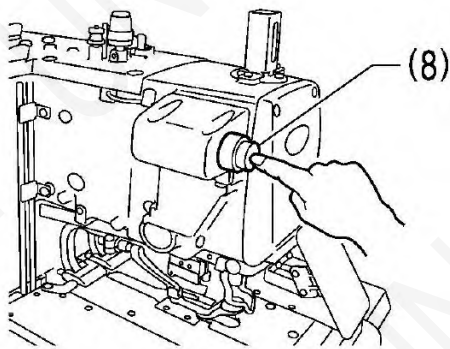
- ⑥ For stopping the manual sewing, press emergence stop switch (8) when the cloth-feeding board returns to the position for laying cloth



The “Pause Switch Is Pressed In Sewing” is

displayed on operation board. Press  to return to sewing interface and then press .



⑦ At Last Stitch

The needle rod stops at the upper position of needle. Step start pedal (7) at this time.

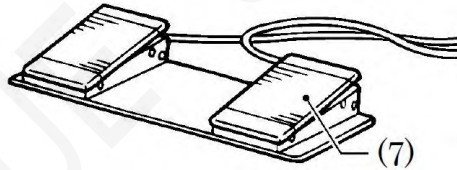

(Hold it until the cloth-feeding board returns to the position for laying cloth.)

In thread-trimming actions, when the cloth-feeding board returns to the position for laying cloth, the system will hint “END OF MANUAL MODE” in the operation panel.

Caution:

When setting knife action as “Cut-after-Sewing”, user shall look out the action of knife.



### 3.3 Pause Switch

#### Pause in Auto Sewing

The pause switch is generally used for stopping the sewing machine at thread-breakage and other circumstance

#### 3.3.1 Methods for Pausing

During the sewing, press the pause switch (1) to stop the sewing machine, and then the operation panel will hint “E-007 Pause Switch is pressed on machine sewing status”.

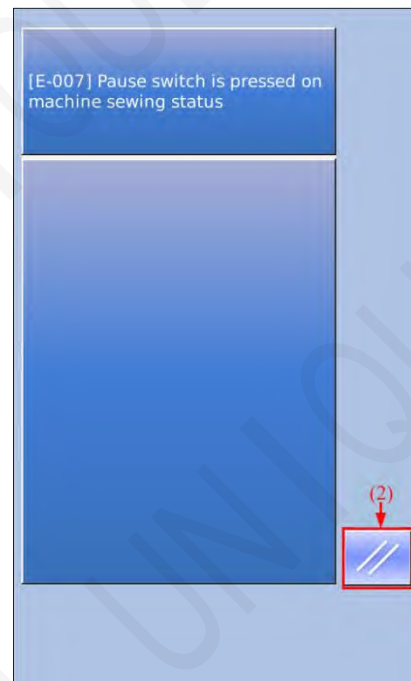
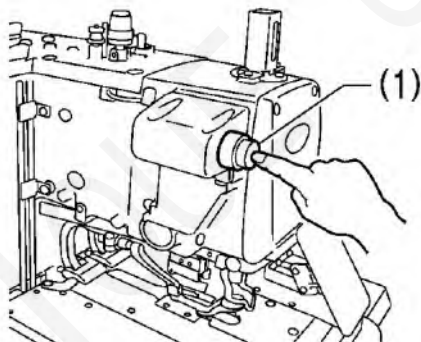

### 3.3.2 Method for Releasing Pause (For Stopping the Work)

- 1 Press  (2) when the interface displays “E-007 Pause Switch is pressed on machine sewing status”

Then the operation panel will show the sewing interface, and the pattern data display area shows “Press ‘Reset’ or ‘Down’”

- 2 Release the error causing the pause.

- 3 Press . After the needle rod and the cloth-feeding board performs the origin test, they will return to the position for setting cloth.





### 3.3.3 Method for Releasing Pause (For Continuing the Work)



- 1 Press  (2) when the interface displays “E-007 Pause Switch is pressed on machine sewing status”

Then the operation panel will show the sewing interface, and the pattern data display area shows “Press ‘Reset’ or ‘Down’”



- 2 Release the error causing the pause.

If the upper thread is broken, press  to have access to the threading mode.

- 3 Press  to display the total stitch number of pattern (3) and the leftover stitch number (4) in the pattern data display area.

- 4 Press  or  to move the cloth-feeding board according to the shape of pattern so as to confirm the position for continuing the sewing job.

If the upper thread is broken, please press  to have access to threading mode.

Note: press  to proceed; press  to reverse. Holding means to keep proceeding or reversing.



- ⑤ Select the position for continuing the sewing, step the start pedal (5) to continue the automatic sewing of the existing pattern.

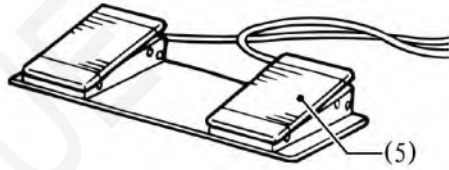

### 3.4 Usage Instructions on Cyclical Sewing Function

In the single pattern program (P01~P20), system can combine several edited single patterns together and register them into a “Cyclical Pattern Program” for continuous sewing, which is easy for using.

#### Cyclical Pattern Program:

Max Amount for Cyclical Patterns	9 个 (C01~C09)
Max Amount of Single Pattern in a Cyclical Pattern	9 个 (S1~S9) (A single P pattern can be selected for many times)

#### Example:



We select a single pattern P01 (3 steps, with knife action) and a single pattern P03 (1 step, without knife action) to combine a cyclical pattern, which is set as C1 for example

The set contents of Cyclical Pattern Program C1:

Step Code of C Pattern	S1	S2	S3	S4
Name of Single Pattern	P01	P01	P01	P03
Knife Action	Yes	Yes	Yes	No

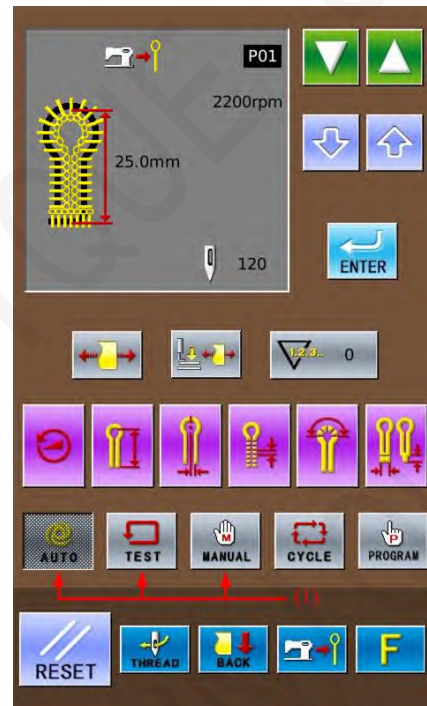
- ① Press the keys (1) at the right interface to select sewing mode in random. (Take the auto mode as example.)





- ② Press   to select C1, the pattern number of that cyclical pattern program  
The pattern code will change in the following sequence: P01→P02→...P20→C1 →C2...C9...P01 at each pressing on .

(Press  to reverse the sequence.)

- ③ Press Cycle Mode Key (2)  
The sewing data display area will show the following contents:

- (3) Step Code
- (4) Cyclic Program Code
- (5) Pattern Content Set in S1.



- ④ Press   to set the content of S1 (5) as P01

The “  ” in “P01” means that this pattern has the knife action, therefore the knife mark (6) is shown in the sewing data display area



“--” in “P--” means the pattern in this step has not been set yet.

If you set the existing pattern as “P--”, the content in the following steps will be deleted.



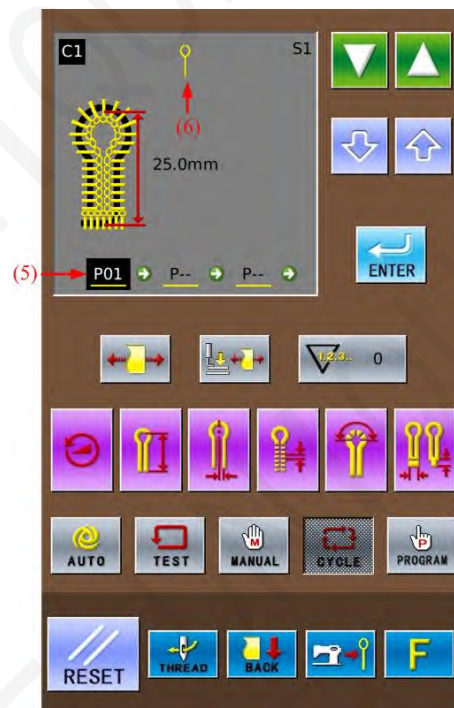

- ⑤ Press  to confirm the changed content.

At that time, the content of S1 (5) will not be shining any more.



- ⑥ Press   to change the step code (3) to S2.
- ⑦ Repeat the operations in steps 4 & 5 at above to set the content of S2 as “P01”, which is as same as that of S1. Repeat the operations in steps 4 & 5 at above to set the content of S3 as “P01”, which is as same as that of S1.
- ⑧ Press  to confirm the changed content.



- ⑨ Press   to change the Step Code (3) to S4.
- Press   to set the content of S4(6) as P03.
- Press Knife Action Key (7) to change the “P03” at (6) to “P03”. (Without Knife Action)
- ⑩ Press  to confirm the changed content.

Press any key in (1) to end the setting in the Cycle Mode

Note: When selecting the cyclical program to perform the automatic sewing, the user can change the knife action in the Auto Mode. And the knife action in the C pattern will be kept same to the knife mode set at present.

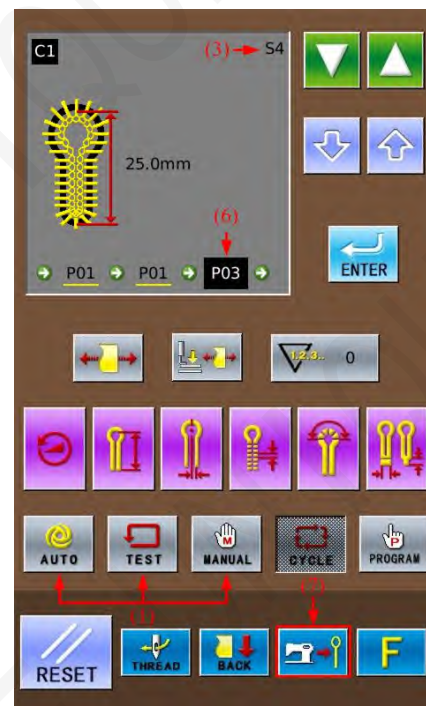

## 4 Interface of Parameter Setting Mode

In the interface for inputting sewing data, press  to shift the data input interface and parameter setting mode interface (as shown in right). In the interface of parameter mode, user can make some detailed settings and edition operations.

In the interface for inputting sewing data, hold  for 3 seconds, then the system will have access to the setting mode Level 2.

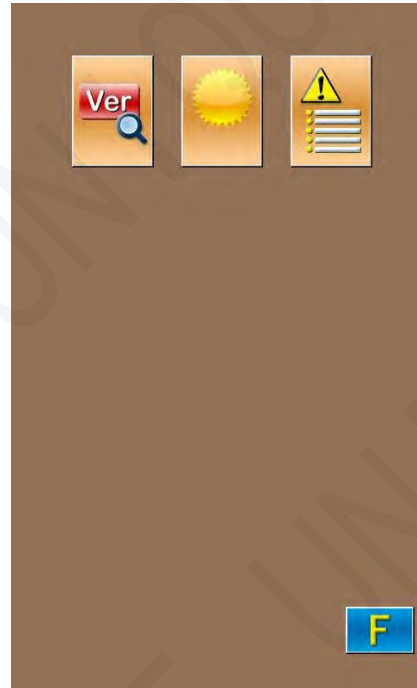



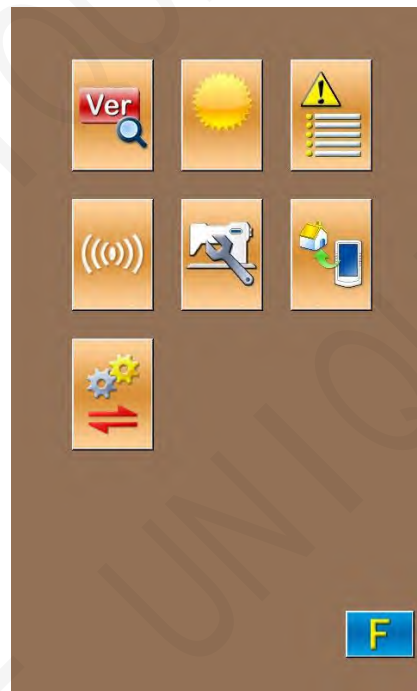



Setting Mode Level 1



Setting Mode Level 2

## 4.1 Description of Functions

### Setting Mode Level 2:

No.	Figure	Functions
1		Inquiry of software version.
2		Lightness adjustment
3		Error information record
4		Communication mode
5		U level parameter
6		Recovery to default setting
7		Parameter back-up & recovery

## 4.2 Software Version Inquiry

In Level 1 of Setting Mode, press  to have access to the interface for inquiring the software version (as shown in the right figure).

- (1): Version of Operation Penal Program
- (2): Version of Controller Program
- (3): Version of Main Motor Program
- (4): Version of X Axis & Y Axis Stepping Motor Program
- (5): Version of Z Axis Stepping Motor Program
- (6): File System Version
- (7): Operation System Version
- (8): Compiling Time of Panel Program

Press  to output the software version to the base inventory of U disk with name version.png.



Panel Ver: SCS11-KD-SJ-v1.0.20

Main-Control Ver: SCS11-MC-SJ-v5.2.219

Main-Motor Ver: SCS11-MM-SJ-v5.2.219

Step-Motor-1 Ver: SCS11-MD-SJ-v1.0.7





Step-Motor-2 Ver: SCS11-MD-SJ-v1.0.7

Fs Ver: SCS11-FS-SJ-v1.0.8

Os Ver: SCS11-OS-SJ-v1.0.6

Compiling Time: 2013-01-6

### 4.3 Lightness Adjustment



In Level 1 of Setting Mode, press  to have access to the interface of lightness adjustment (as shown in the right figure), whose range is from 20 to 100. User can press  or  to adjust the value and it is also possible to input the value via the number keys. Press  to confirm the input.



### 4.4 Error Information Record

In Level 1 of Setting Mode, press  to have access to the interface for recording the error information (as shown in right). In the interface, the times of the various kinds of errors and the recent error information will be displayed. The smaller number means the later occurrence.

Additionally, the system will also record the production number at each warning.

User can use  or  to turn the pages for checking more error information.

Press  to clear all the error records.



## 4.5 Communication Function

The communication mode contains the following functions:

- 1、 Update Panel Software via U Disk;
- 2、 Transfer U Level Parameters between Panel and U disk

### 4.5.1 Operation Penal Update

① **Have access to the interface of communication function**

Insert U disk, in Level 2 of Setting Mode,

press  to have access to the communication function mode (as shown in the right figure).

 : Software Update



## ② Enter Software Update Interface

Press  to enter the software update interface (as shown in right), where user can update the software

The updating software is located at 「update」 in U disk. Click the content for update,

then please press .

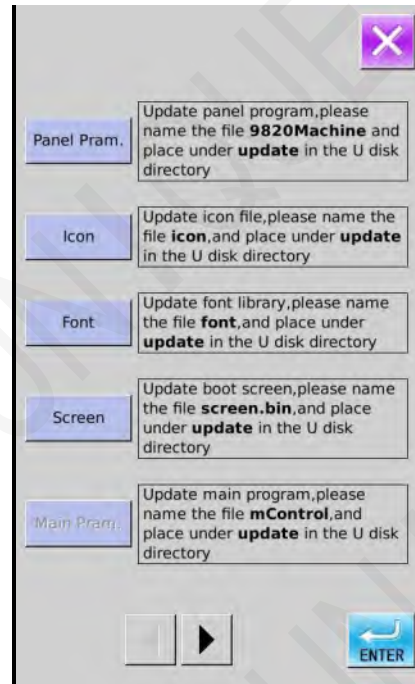

## ③ Finish Updating

After the update, the system will display the hint information. Please restart the machine.



## 4.5.2 Input/ Output of Parameters

### ① Display the Communication Interface

Insert U disk. In the level 2 of Setting Mode,

press  to have access to the Communication function mode

A: Input Parameter from U disk to Panel

B: Output Parameter from Panel to U disk

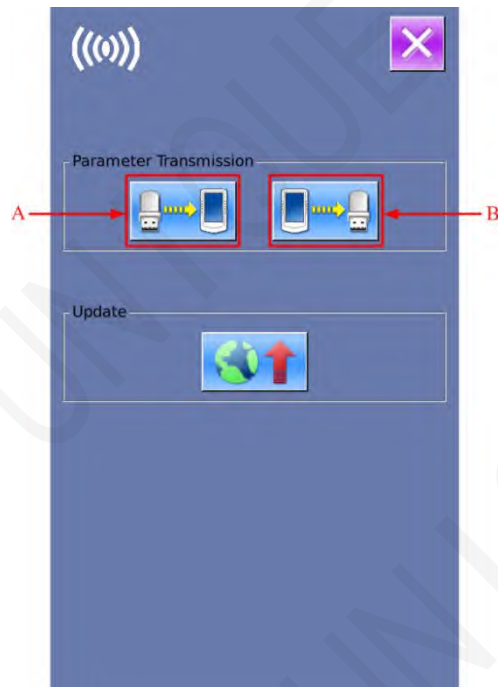

- ※ When inputting patterns from U disk, user has to save the parameters into the DH\_PARA in the U disk with name 9820Param
- ※ When outputting patterns from operation panel, user has to save the parameters into the DH\_PARA in the U disk with name 9820Param
- ※ The parameter file is the binary file, which is operated on the control panel. User can not change that file manually on PC, or the file may be damaged.



### ② Press Button A to Input Parameters from U Disk to Operation Panel

A、 Press  to input the parameters and quit

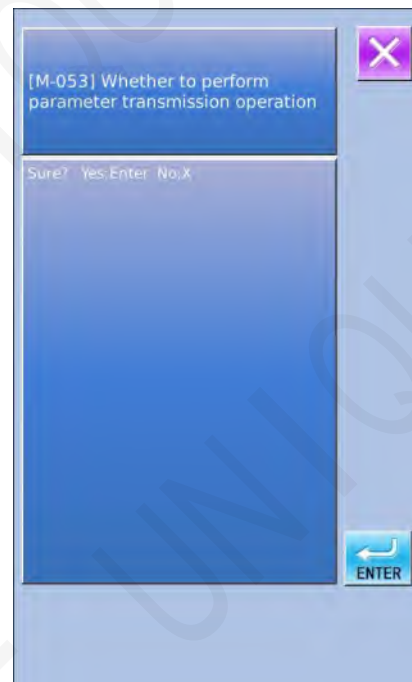
B、 Press  to quit directly.



③ **Press Button B to Output Parameters to U Disk**

- A、 Press  to output parameters from operation panel to U disk and quit
- B、 Press  to quit directly



## 4.6 Parameter Setting

### 4.6.1 Method for Setting Parameters

#### ① Have Access to Parameter Setting Interface

In Level 2 of Setting Mode, press  to have access to the interface for setting U level parameters (as shown in right picture).

Press  to quit the setting interface

When some parameters are changed, the system will display the “Modified” in the parameter setting interface.

Select the parameter for changing; Then the system will enter the setting status. The parameters are separated as “Data Input Type” and “Selection Type”. Please refer to the example at below:

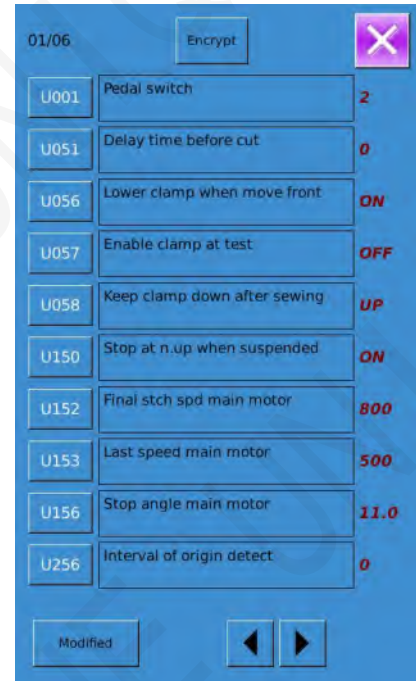

Input Type

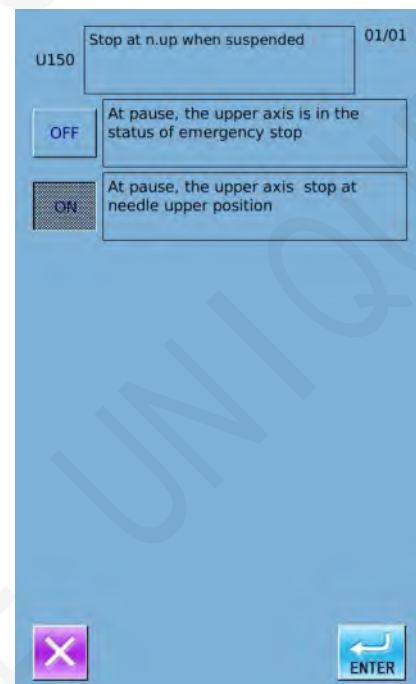

Selection Type

② **Parameter Encryption**

Press “Encryption” to enter the password input interface.

Press  to clear all the content

Press  to erase one figure at each pressing

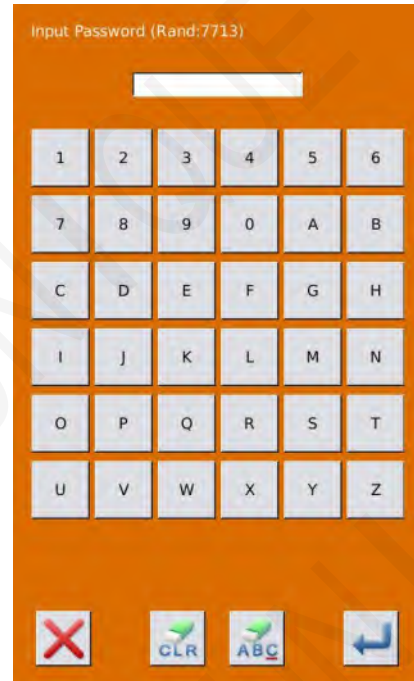

③ **Change the Parameter**

Input the right password to enter the interface for parameter encryption

A、 Select the parameter for encryption

B、 Press **【Select All】** to attach password to all the parameters

C、 Press **【Reverse】** to select parameter for encryption in reverse way

D、 Press  to quit the encrypting function



④ Check the changed parameter

A、 When parameter is changed, the system will display “Modified” key at parameter setting interface.

B、 In the parameter setting interface, press **【 Modified 】** to check the changed parameters.

At first, the system will ask user to input the password. For the operation at password input interface, please refer to the “A” at ②.

After inputting the right password, user can enter the interface for inquiring changed parameters.

C、 Under the interface of changed parameter inquiry, user can find the list containing all the changed parameters with their current value and default value.

In that interface:

- Press **【 All Rest 】** will restore all the changed parameters to their default values
- Click Parameter Name, like **【 Limit maximum cut Space 】** and then press **【 Select Rest. 】** to restore this parameter to the default value. User can select many parameters at here.
- Press Parameter Number, like **【 U453 】** to enter the parameter setting interface, where user can reset the parameter value.

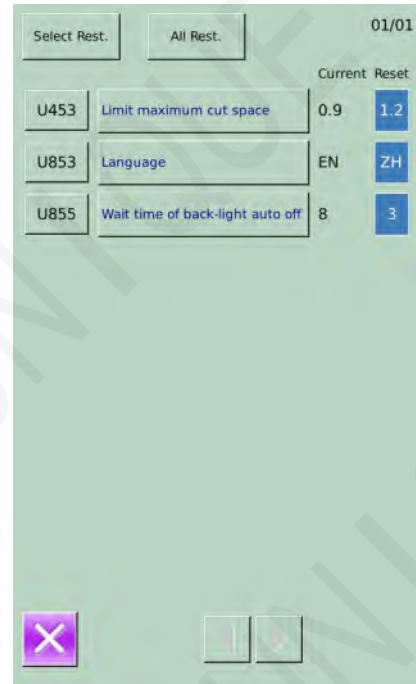

### 4.6.2 List of Parameters at U Level

No.	Functions	Description	Range	Default Setting
U001	1 Pedal/2 Pedals Switch	1: Step the start pedal to lower the presser, and the sewing machine starts. 2: Press the presser switch to lower the presser. Then step the start pedal to start the sewing machine.	1~2	2
U051	Delay time before cut for 1 Pedal model	For automatic sewing in Cut-before-Sewing mode, this parameter will determine the delay time of knife action after the pedal 1 is stepped	0~800	0
U056	Lower clamp when move front	0: OFF After sewing, the cloth-feeding board moves to the position set before with the presser at up position; the presser keeps up at searching the original	0~1	0

No.	Functions	Description	Range	Default Setting
		<p>1: ON</p> <p>After sewing, the presser doesn't rise until the cloth-feeding board moves to the position for laying cloth; during the process of searching origin, the presser keeps going down when each axis return to origin. The presser doesn't rise until the frame goes to the position for laying cloth.</p>		
U057	Enable clamp at test	<p>0: OFF</p> <p>The raise of presser is forbidden in test mode</p> <p>1: ON</p> <p>In Test mode, the following operations can make presser go up:</p> <p>(A): Manual switch type or double pedal type: press presser switch</p> <p>(B): pedal type: return to pedal</p> <p>In restarting the test mode, the following operations have to be done for lowering the presser</p> <p>(A): Manual switch type or double pedal type: press presser switch</p> <p>(B): pedal type: return to pedal</p>	0~1	0
U058	Clamp action after sewing	<p>0: Up</p> <p>Presser goes up when the automatic sewing is finished</p> <p>1: Down</p> <p>Presser keeps going down when the automatic sewing is finished. Please perform the following operations when the presser rise:</p> <p>(A): Manual switch type or double pedal type: press presser switch</p> <p>(B): pedal type: return to pedal</p>	0~1	0
U150	Stop with needle up at pause	<p>0: After activating emergency stop, the main shaft stops immediately at any position;</p> <p>1: After activating emergency stop, the main shaft stops at needle upper position (normal stop position)</p>	0~1	1
U152	Final stch spd main	Set speed of the last stitch	700~90 0	800

No.	Functions	Description	Range	Default Setting
	shaft			
U153	Last speed main shaft	Set the stop speed	250~450	350
U156	Stop angle main shaft	The stop control section will be prolonged when this value goes up.	2.5~17.5	11.0
U256	Interval of origin detect	0: OFF Do not detect origin after sewing 1~9: Detect the origin position after sewing in certain times.	0~9	0
U301	Parameter confirmation column in Auto Mode	Make the quick parameter setting		1
U350	Forbid Program Mode	Determine whether to lock pattern, and pattern cannot be changed after setting this parameter		0
U351	Forbid Cycle Mode	Set the validity of the cycle mode, to determine whether to allow C pattern setting		0
U352	Forbid to change counter	0: OFF General Conditions 1: ON Forbid to change the value in products counter	0~1	0
U353	Forbid to edit sewing speed	Determine whether to allow speed setting, that is, the adjustment of the maximum speed		0
U354	Forbid to edit the program code	Determine whether to allow pattern number modification		0
U355	Forbid to change to Cut-before-Sewing	Determine whether to allow cut-before-sewing, 0: Yes, 1: No	0~1	0
U356	Forbid to change to Cut-after-Sewing	Determine whether to allow cut-after-sewing, 0: Yes, 1: No	0~1	0
U359	Waste material collection	Set the validity of waste material collection, 0: invalid, 1: valid	0~1	0
U357	Safe Switch	0: OFF Safe Switch Invalid 1: ON Safe Switch Valid	0~1	1
U450	Max sewing speed	Set the Max sewing speed	1000~2700	2700
U451	Max cycle program number	Set the number of C pattern	0~9	9
U452	Product count for cycle pattern	0: Count after sewing a pattern 1: Count after sewing a C pattern	0~1	0
U453	Max knife interval	Set the max knife interval	0.5~1.0	0.5
U454	Max linear bar-tacking length	Set the max length of linear bar-tacking	6~9	6
U455	Additional needle swing at Non-cut	If the Non-cut is used, the needle swing will be added automatically.	0~1.0	0

No.	Functions	Description	Range	Default Setting
U456	Adjustment of needle swing at start	Set adjustment of needle swing at sewing start	-1.0~0 mm	0
U457	Adjustment of main shaft speed	Adjust the speed of the main shaft	-900~0 rpm	0
U458	Bar-tacking vertical turning speed	Set the speed at the start of the sewing of the linear bar-tacking	200~900rpm	900
U550	Time for air-hammer ON	The larger value, the longer contact time between air-hammer and knife will become.	25~200	25
U551	Air-hammer origin height	In readiness status, Error code E650 will be activated when the value of air-hammer position sensor is smaller than this value. (only effective when the air-hammer origin error detection is turned on)	150~170	160
U552	Air-hammer origin error detection	0: OFF No air-hammer origin error detection (used when the air-hammer position sensor is down) 1: ON Have air-hammer origin error detection	0~1	1
U553	Determine air-hammer rise position by time	0: OFF According to position of air-hammer to detect the lowering of air-hammer 50~500: Detect the lowering of air-hammer according to time (used when the air-hammer position sensor is down)	0~500	0
U554	Determined air-hammer lowering by time	0: OFF Determine the position of air-hammer for lowering. 50~500: Detect the lowering of the air-hammer according to time (used when the air-hammer position sensor is down.)	0~500	0
U555	Increase of leftover upper thread	0: OFF General Conditions 1~3: Because only the sequence delay of trimming upper thread is set, the leftover upper thread may be increase after sewing.	0~12	0
U556	Time for losing upper thread	The larger value, the longer the time for losing upper thread after thread-trimming.	0~100	50
U557	Upper thread-losing Off Sequence	0~100: the larger value is, the later the thread-losing OFF time after trimming will be.	0~100	50

No.	Functions	Description	Range	Default Setting
U558	Forbid to use bottom thread trimmer device	0: OFF General Conditions (Bottom thread trimmer device is activated) 1: ON Forbid to use bottom thread trimmer device	0~1	1
U559	Neglect of bottom thread knife sensor and counter	0: OFF Detect the bottom thread knife device is off according to the OFF sensor of bottom thread trimmer 5~50: Detect the bottom thread knife device is off according to time. Set this parameter with a step at 5ms	0~50	0
U560	Bottom thread-trimming time	0~100: the larger value is, the later the thread-trimming time will be.	0~100	0
U561	Upper thread-breakage sensor	Not available		0
U562	Stitch number before action of upper thread-breakage sensor	Not available		5
U563	Stitch number for judging upper thread-breakage	Not available		4
U564	Upper thread-catching device	Not available		0
U565	Upper thread-catching close time correction	Not available		0
U576	Upper thread-catching open time	Not available		10
U577	Frame-moving Method	0~5 : select different frame-moving method	0~5	1
U578	Frame-moving adjustment 1	-50~50: Adjust the XY frame-moving angle	-50~10 0	0
U579	Z axis frame-moving adjustment	-50~50: Adjust Z axis frame-moving angle	-50~50	0
U580	Upper thread taking-up action time	0~200: Start time adjustment of upper thread taking-up	0~200	0
U581	Upper thread tension adjustment	0~250: Adjust upper thread solenoid current	0~250	230
U582	Presser boost air-hammer action interval	Set the time for the action of presser boost air-hammer after the action of main air-hammer	0~100 ms	50
U583	Waste collection air valve action time	Set the action time of waste collection air valve	200~800ms	500
U584	X frame-moving time adjustment	Adjust the frame-moving time of X axis	-3~5ms	0

No.	Functions	Description	Range	Default Setting
U585	Y frame-moving time adjustment	Adjust the frame-moving time of Y axis	-5~5ms	0
U586	Fast moving time adjustment	This value is used to adjust the speed of the fast moving of the cloth-feeding board; the smaller the value is, the faster the cloth-feeding board moves.	100~-1 20	-100
U588	Frame-moving adjustment 2	Not available		0
U650	Time to buzzer stop/fan detection	This value is to set the buzzer status in case of error alarm; however, as for ZOJE 9820, this value is to control the detection of the cooling fan status (EB028); when set as 0, to activate the detection, otherwise not.	0~15S	0
U651	Motor excitation status at error	This value is used to control whether to loose X/Y/Z axis when control system reports error	0~1	0
U752	Adjustment of X position on knife	The set value is the adjustment of X position on knife, which will be added into entire pattern program.	-0.50~0 .50	0
U850	Sewing machine head configuration	0: -00 Set configuration as -00 1: -01 Set configuration as -01 2: -02 Set configuration as -02	0~2	0
U852	Radial Hole Presser	0: OFF Use general presser (except that of radial hole) 1: ON Use the special program for radial hole presser. The displayed is the special parameter for radial hole.	0~1	0
U853	Language	0: Chinese 1: English	0~1	0
U854	Backlight auto Off	Whether to activate backlight auto off	0~1	0
U855	Backlight auto off wait time	Set the waiting time of the backlight auto off		3
U856	Button display style	Set the display style		0
U857	Voice Volume	Set the voice volume of the buzzer		0
U858	Password setting/lamp brightness control	Set whether password is needed to start the machine.	0~5	0
U911	Air hammer down detection adjustment	Set adjustment of hammer lowering detection	0~60	15
U912	Main shaft motor type/Y axis origin	Not available to machines of other manufacturers and only	0~1	ZOJE, SHNJA:

No.	Functions	Description	Range	Default Setting
	searching method	open to ZOJE 9820, for its Y axis sensor used to be installed at the front, but now is installed at the back after finalizing of the machine. When set as 1, the sensor shall be installed at the back, but when set as 0, the sensor shall be installed at the front under the cloth-feeding board.		1 Others: 0
U913	DIP1	Temporary adjusting parameter (reserved)	-100~100	0
U913	DIP2	Temporary adjusting parameter (reserved)	-100~100	0

#### 4.7 Initialization of Parameters

- ① In level 2 of setting mode, press  to have access to interface of parameter initialization, as shown in right:

User can select:

- (1) LEVEL1: Para. And C Program ( Level S pattern parameter and C pattern cycle program)
- ( 2 ) LEVEL2 : Storage Data (Including U level parameters)
- (3) LEVEL3: All Internal Data
- (4) LEVEL4: Initialize U disk

The detailed initialization content is at below

Level, Content & Clear of Initialization			
	LEVEL1	LEVEL2	LEVEL3
Program Content	Default value	—	Default value
Cycle program	Clear	—	Clear
Storage switch	—	Default value	Default value
Program code	1	—	1
Parameter code	1	—	1
Production counter	—	—	0
Mode	Program	—	Program
Position for locating cloth	Built-in	—	Built-in
Knife action	OFF	—	OFF

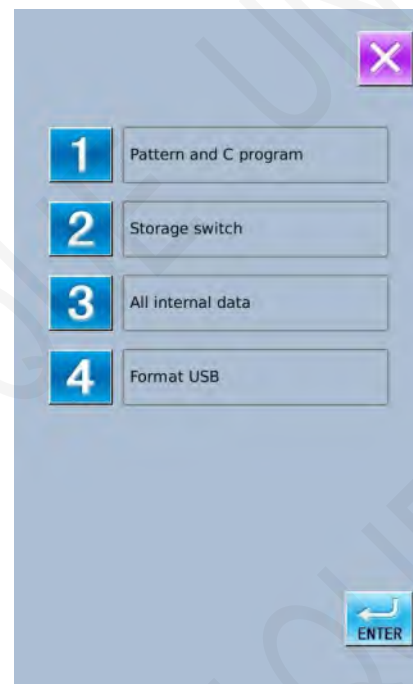

- ② Select the parameter for initialization, then press  for confirmation.

The right interface will be displayed on the screen, press  to initialize the parameter.



## 4.8 Parameter Back-up & Recovery

User can save 8 groups of U level parameter for future use.



In setting mode level 2, press  to enter the interface of parameter back-up & restoration, as shown in right:

Clear: Clear all the customized parameters that are saved.

Save: Save current parameters

Restore: Restore the current parameters

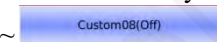
- ① Click any key among  ~  to set the position for saving the parameter. And then press 「 Save 」 to save that parameter.

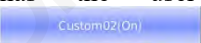
- ② Check the content on 「 Custom xx ( On/Off ) 」 . If 「 On 」 is displayed in bracket, that means this position has the user parameter, for an example 

- ③ Select the button with parameters, press 「 Restore 」 to reload the corresponding parameter values

- ④ Press 「 Clear 」 to delete all the saved parameters

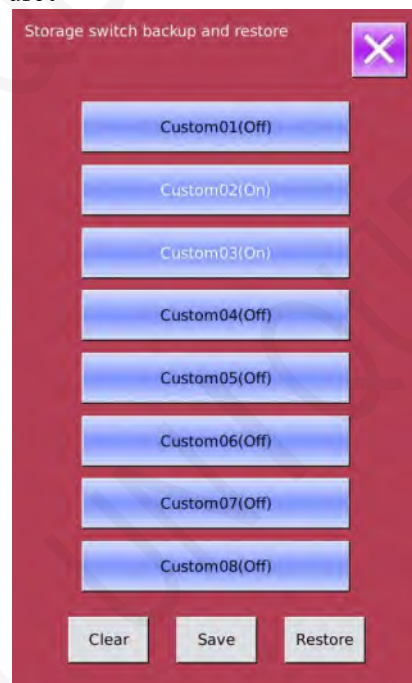

## 5 Appendix 1

### 5.1 List of Warning Information

Malfunction code	Name of Malfunction	Method for Settlement
<b>System Malfunction</b>		
E-001	IPM over-voltage or over-current	Turn Off Machine
E-002	Supplementary device (24V) over-voltage	Turn Off Machine
E-003	Supplementary device (24V) low-voltage	Turn Off Machine
E-004	EEPROM Error	Turn Off Machine
E-005	Motor running error	Turn Off Machine
<b>Special Malfunction</b>		
E-006	Press Pause key at ready status	Release pause key
E-007	Press Pause key at sewing status	Press RESET
E-008	Pause Key bad connection	Turn Off Machine
E-009	Start Switch is held or bad connection at start switch	Release the start switch or turn off machine. And check the connection
E-010	Presser Switch is held or bad connection at presser switch	Release the start switch or turn off machine. And check the connection
E-011	Machine head is tilted.	Turn Off Machine
E-012	Needle bar upper position abnormal	Turn wheel to upper position
E-013	Synchronization signal detector connection error	Turn Off Machine
E-014	Can not find X feeding motor origin. X feeding motor abnormal or bad connection at X origin sensor	Turn Off Machine
E-015	Can not find Y feeding motor origin. Y feeding motor abnormal or bad connection at Y origin sensor	Turn Off Machine
E-016	Can not find $\theta$ feeding motor origin. $\theta$ feeding motor abnormal or bad connection at $\theta$ origin sensor	Turn Off Machine
E-017	IPM Over-current	Turn Off Machine
E-018	IPM Over-current	Turn Off Machine
E-019	Program version of main controller or motor error.	Turn Off Machine
E-020	Upper thread-breakage	Press RESET
E-021	Bottom thread-trimming device not work or bottom thread-trimming sensor abnormal	Turn Off Machine
E-022	Hammer is lowered or hammer position sensor is abnormal	Turn Off Machine
E-023	Hammer is not lowered or hammer position sensor is abnormal	Turn Off Machine
E-024	Power over-voltage	Turn Off Machine
E-025	Stepping motor over-voltage	Turn Off Machine
E-026	Power low-voltage	Turn Off Machine
E-027	Stepping motor over-current	Turn Off Machine

<b>Malfunction code</b>	<b>Name of Malfunction</b>	<b>Method for Settlement</b>
E-028	Fan not work	Turn Off Machine
E-029	Hammer can not go down	Turn Off Machine and Increase Knife Pressure
E-030	Stepping board communication abnormal	Turn Off Machine
E-031	X motor running abnormal	Turn Off Machine
E-032	Y motor running abnormal	Turn Off Machine
E-033	Cloth board over--range	Turn Off Machine
E-034	Z motor running abnormal	Turn Off Machine
E-035	Motor close loop abnormal	Turn Off Machine
E-036	Main-shaft 0 position signal error	Turn Off Machine
E-037	Main-shaft encoder error	Turn Off Machine
E-038	Main-shaft stop abnormal	Turn Off Machine
E-039	Sewing stop abnormal	Turn Off Machine
E-040	SPI communication busy	Turn Off Machine
E-041	Stitch signal error	Turn Off Machine
E-042	X motor busy	Turn Off Machine
E-043	Y motor busy	Turn Off Machine
E-044	Z motor busy	Turn Off Machine
E-045	Pattern stitch number error	Turn Off Machine
E-046	Main-shaft speed abnormal	Turn Off Machine
E-047	No encryption device	Turn Off Machine
E-048	Wrong password 1	Turn Off Machine
E-049	Wrong password 2	Turn Off Machine
E-050	Low pressure	Turn Off Machine
E-051	X motor over-current	Error reported from ATASC511 stepping board, indicating abnormal current of X motor. Please check whether the red LED lights surrounding stepping board DSP1 are on.
E-052	Y motor over-current	Error reported from ATASC511 stepping board, indicating abnormal current of Y motor. Please check whether the red LED lights surrounding stepping board DSP1 are on.
E-053	X motor position error	Error reported from ATASC511 stepping board, indicating abnormal position of X motor. Please check whether the red LED lights surrounding stepping board DSP1 are on.
E-054	Y motor position error	Error reported from ATASC511 stepping board, indicating abnormal position of Y motor. Please check whether the red LED lights surrounding stepping board DSP1 are on.

<b>Malfunction code</b>	<b>Name of Malfunction</b>	<b>Method for Settlement</b>
E-055	X motor over-speed	Error reported from ATASC511 stepping board, indicating abnormal speed of X motor. Please check whether the red LED lights surrounding stepping board DSP1 are on.
E-056	Y motor over-speed	Error reported from ATASC511 stepping board, indicating abnormal speed of Y motor. Please check whether the red LED lights surrounding stepping board DSP1 are on.
E-057	DSP1 Communication Abnormal	Communication error between the main board and the stepping board of ATASC511 system, and failed validation of SPI communication Check the three LED indicators of stepping board MD1; if all are on, it means the stepping board fails to validate the communication data; if all are off, it means the main control board fails to do so
E-058	Z motor over-current	Error reported from ATASC511 stepping board, indicating abnormal current of Z motor. Please check whether the red LED lights surrounding stepping board DSP2 are on.
E-059	Not Available	
E-060	Z motor position error	Error reported from ATASC511 stepping board, indicating abnormal current of Z motor. Please check whether the red LED lights surrounding stepping board DSP2 are on.
E-061	Not Available	
E-062	Z motor over-speed	Error reported from ATASC511 stepping board, indicating abnormal current of Z motor. Please check whether the red LED lights surrounding stepping board DSP2 are on.
E-063	Not Available	
E-064	DSP2 Communication Abnormal	Communication error between the main board and the stepping board of ATASC511 system, and failed validation of SPI communication Check the three LED indicators of stepping board MD2; if all are on, it means the stepping board fails to validate the communication data; if all are off, it means the main control

Malfunction code	Name of Malfunction	Method for Settlement
		board fails to do so

## 5.2 Hint List

No.	Name	Content
M-001	Set value too large	Please input value within range
M-002	Set value too small	Please input value within range
M-003	Parameter save error	Press Enter to recover default setting
M-004	Communication error	Communication error between operation panel and control box
M-005	Operation head not match to control box	Please check the model and the software version
M-006	Clock error	The hardware clock is down, please contact manufacturer for repair
M-007	Wrong password	Input again
M-008	Wrong user ID	Input again
M-009	Fail to confirm password	Input password again
M-010	Can not change system time	Periodical password has been set, can not change system time
M-011	Password file input error	
M-012	Password file load error	
M-013	Password save successful	
M-014	Clear all password failed	Can not delete password file
M-015	Fail to clear password	After clearance of password, the input of file has problem
M-016	Password file is deleted without authorization	Password file is deleted without authorization, please turn off machine
M-017	Can not input blank	Input password again
M-018	Current password not match	Input current password again
M-019	New password not match	Input new password again
M-020	Periodical password is same to super password error	Input password again
M-021	Enter touching panel correction mode	Are You Sure? Yes: enter No: X
M-022	Correction successful	Correction is successful, please restart machine
M-023	Correction failed	Please perform correction again
M-024	SRAM initialization	Clear all the data within SRAM, please turn off machine and restore the DIP switch
M-025	Turning off	
M-026	No warning record	
M-027	Clear warning record	Are You Sure? Yes: enter No: X
M-028	USB is pulled out	USB is pulled out
M-029	Save software version successful	Software version is saved to the root directory of U disk
M-030	Counter at set value	Press ENTER to release it
M-031	Over sewing range	Please make sure the pattern is within the sewing range

No.	Name	Content
M-032	Stitch number over range	Please reduce patter stitch number
M-033	Load default patterns	No pattern in memory, please load default patterns
M-034	Pattern data error	Current pattern data error, it will be replaced by default patterns
M-035	Pattern information file open failed	Restore to default pattern configuration
M-036	Restore to default setting	Press Enter to perform operation; Press ESC to quit
M-037	Parameter recovery successfully	Successful recovery of parameter. Please restart machine
M-038	Restore all the settings	Are You Sure? Yes: enter No: X
M-039	Restore the selected items	Are You Sure? Yes: enter No: X
M-040	Not select an item	Please select one or several parameters
M-041	Successful	Current operation is successful
M-042	Failed	Current operation is failed
M-043	Initialize U disk	Press Enter to perform operation; Press ESC to quit. The initialization will delete all the files in U disk
M-044	Initialize memory	Press Enter to perform operation; Press ESC to quit. The initialization will delete all the files in memory
M-045	Please turn off machine	Current operation is finished, please restart machine
M-046	Not select update item	Please select at least one item for update
M-047	Selected item for update is not existed	If the item has no update file, the system will cancel the selection. If user wants to update the rest, please confirm again
M-048	Update successful	Update successful, please restart machine
M-049	Verification failed at updating main control software	
M-050	Copy failed	Check the room of memory
M-051	Copy failed,	Check whether the U disk is pulled out
M-052	File I/O error	File I/O error
M-053	Parameter transfer	Are You Sure? Yes: enter No: X
M-054	Pattern-designing data error	
M-055	Cyclic sewing pattern open error	Pattern file has mistake
M-056	Open file failed	Open file failed
M-057	Clear all customized parameters	Are You Sure? Yes: enter No: X
M-058	Over set range	

### 5.3 Malfunction Settlement

Malfunction	Reasons	Solutions
Thread-breakage	Thread-tension is so high.	Adjust the thread-tension to proper level
	The needle is not properly installed.	Install the needle in the right direction
	Compared to needle, the thread is so thick.	Select the thread fitting to the needle
	The needle doesn't match to the bend needle.	Adjust the pitch between the needle land bend needle, as well as the height of needle rod, bend needle and yarn divider.
	There is damage or rags on needle, bend needle, yarn divider, winding plate or thread rail.	Polish or replace the rough parts.
	Threading method is wrong.	Thread correctly.
Needle-jumping	The upper thread tension is too large or too small.	Adjust the upper thread tension to a proper level
	The needle tip is broken or crooked.	Replace for a new needle
	The interval between needle and bend needle tip is incorrect.	Adjust the interval between the needle and bend needle tip to a proper level.
	The needle, bend needle and yarn divider don't match to each other.	Adjust the relationships among these three.
	The needle and needle stand are not adjusted properly.	Properly adjust the needle stand.
	The bend needle tip is blunt.	Polish it or replace it.
	The needle is not properly installed.	Install the needle in right direction.
Needle-breakage	The needle is too thin.	Select needles fit the sewing conditions
	The needle is crooked	Replace a new needle
	The needle, bend needle and yarn divider don't match to each other	Adjust the relationships among these three.
	The needle and needle stand are not adjusted properly.	Properly adjust the needle stand.
Upper thread is not cut off.	The needle is too thin.	Select needles fit the sewing conditions
	The upper knife is not so sharp	Replace a new upper knife
	The pressure is too low to let upper knife cut to bottom.	Adjust the pressure
	The upper knife can't catch the upper thread.	Install a upper thread bend needle, and cut the thread at the stitch before the last one
	At the last stitch, the upper knife can't catch the upper thread due to the needle-jumping	Refer to "Needle-jumping", try to avoid the needle from jumping
Bottom thread is not cut off.	The position of upper knife is improper	Adjust the position of upper knife
	The knife is not so sharp.	Replace a new knife.
	The pressure is too low to let upper knife cut to bottom	Adjust the pressure
	The position of knife is improper	Adjust the position of the knife and thread-scanner
	The pressure on knife for trimming bottom thread is too low	Adjust to a proper knife pressure level

Stitch-missing at sewing start	Can't hold bottom thread.	Adjust the bottom thread holder (configuration 01) or bottom thread pressing board (configuration 02)
	The leftover part of the upper thread after trimming is too short.	Adjust the assistant thread holder.
	The released upper thread is far from sufficient.	Adjust the amount of released upper thread.
Cutting function abnormal	Low pressure on cutting device	Adjust the pressure to a proper level
	Knife doesn't properly contact to the cutting hammer	Polish the surface of cutting hammer
	The knife is not so sharp.	Replace a new knife.
Low thread density	The tension of upper thread is so strong or so weak	Adjust the upper thread tension to a proper level.
	The tension of bottom thread is so strong or so weak	Adjust the bottom thread tension to a proper level.
	The strength and stroke of take-up spring are improper.	Adjust the strength and stroke of take-up spring.

## 6 Appendix 2

### 6.1 Installation Size of Control Box

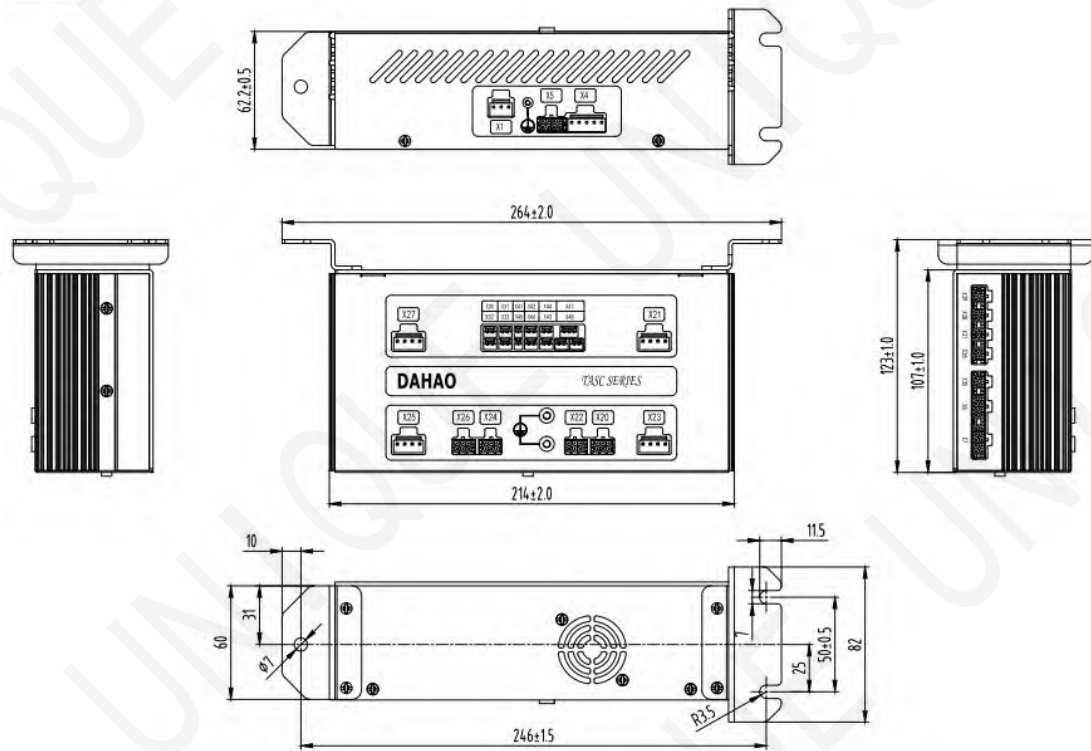

### 6.2 Installation Size of Control Box

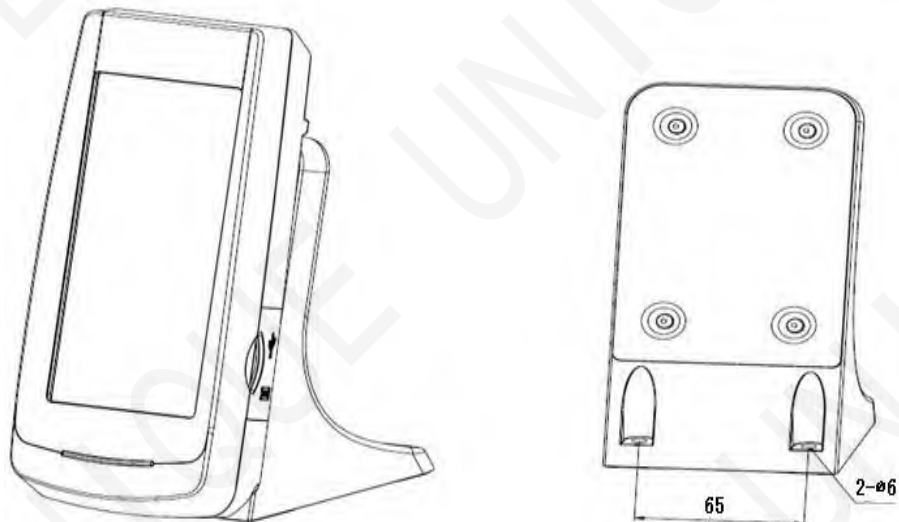

### 6.3 Machine System Diagram

#### 1.TASC511 System Diagram

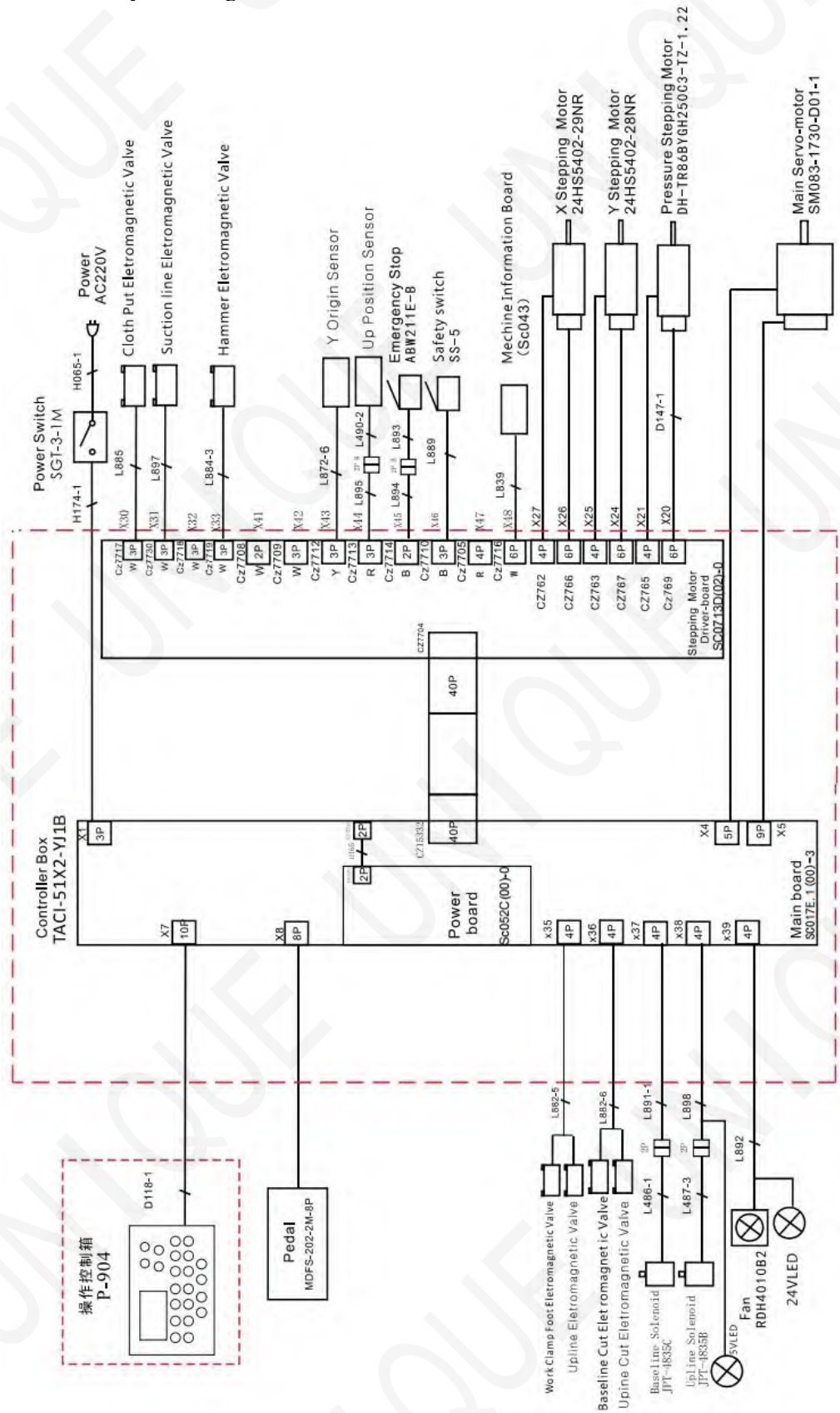

## 2.MASC511 System Diagram

